

	CHAMBER	Volume (gal)
①	Sedimentation Chamber	1,200
②	Anaerobic Filtration Chamber	1,198
③	Aerobic Contact Filtration Chamber	550
④	Storage Chamber	268
⑤	Disinfection Chamber	17
Total Volume		3,233

SPECIFICATIONS			
Anaerobic Media	PP / PE	Filling Rate	47%
Board Type Aerobic Media	PVC / PP / PE	Filling Rate	17%
Aerobic Media	PP / PE	Filling Rate	56%
Blower	7 cfm		
Tank	FRP		
Piping	PVC / PP / PE		
Access Covers	Plastic / Cast Iron		
Disinfectant (Optional)	Chlorine Tablets		

CE30	
Standard Hydraulic Load	2700 GPD

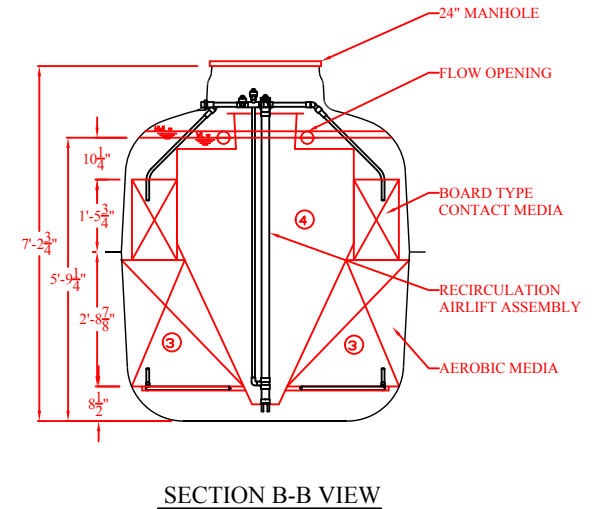
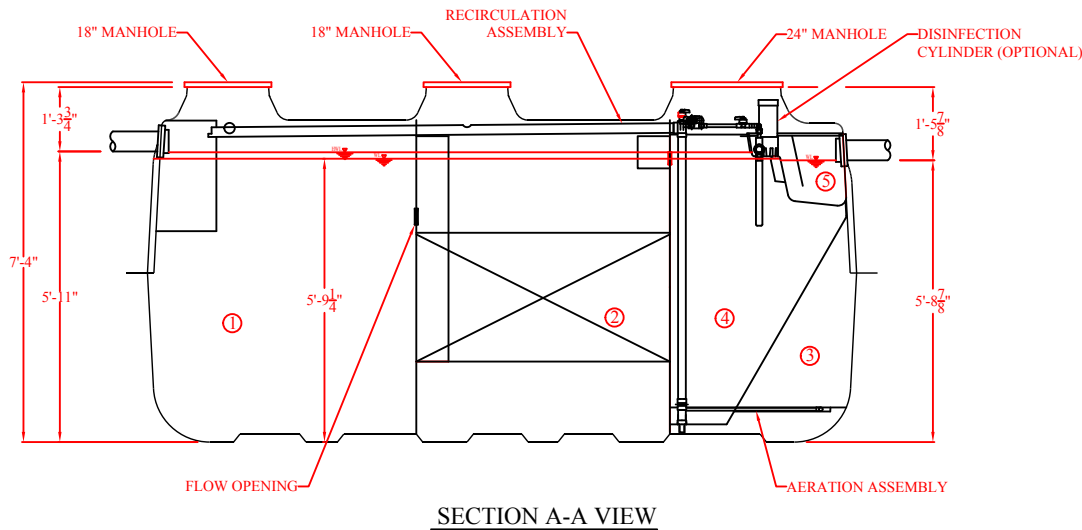
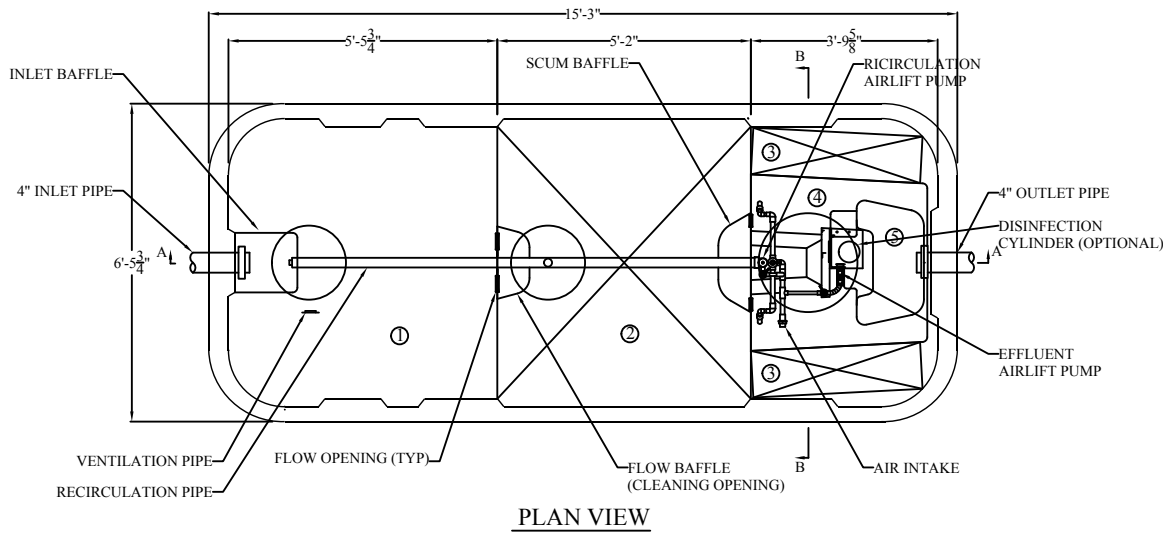

FUJI CLEAN CE30 STRUCTURAL DRAWING

SCALE:
1/4" = 1"
DATE:
05/21/2014
DRAWN BY:
BDB

